

A200



Electric Charriot

areEquipment



A200. Electric Charriot

- Light structure – partially in Aluminium
- Tilt to ease the entry of the table
- 3 attachment points
- Transverse and longitudinal movements
- Electrically powered movement for in and out of the stretcher

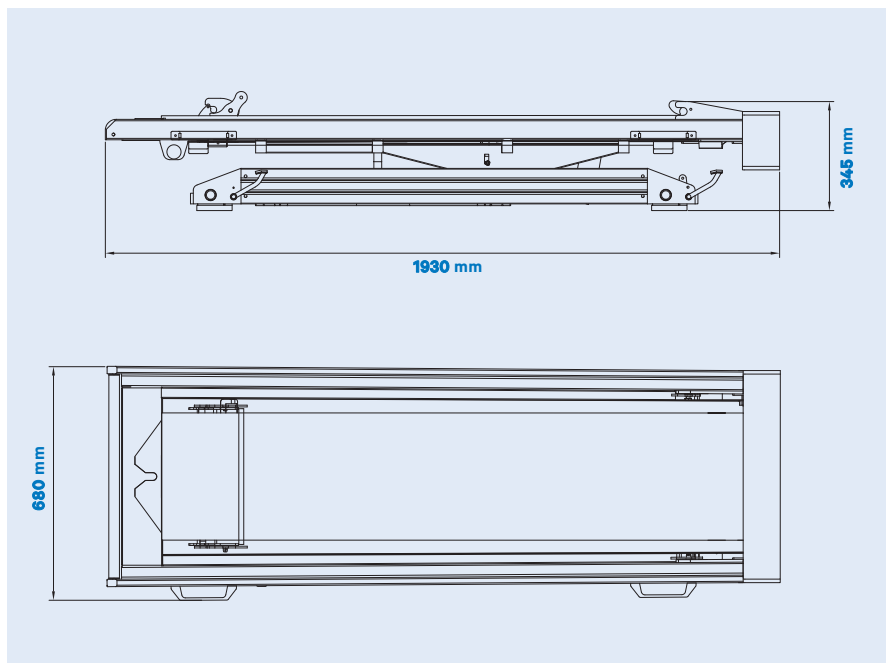
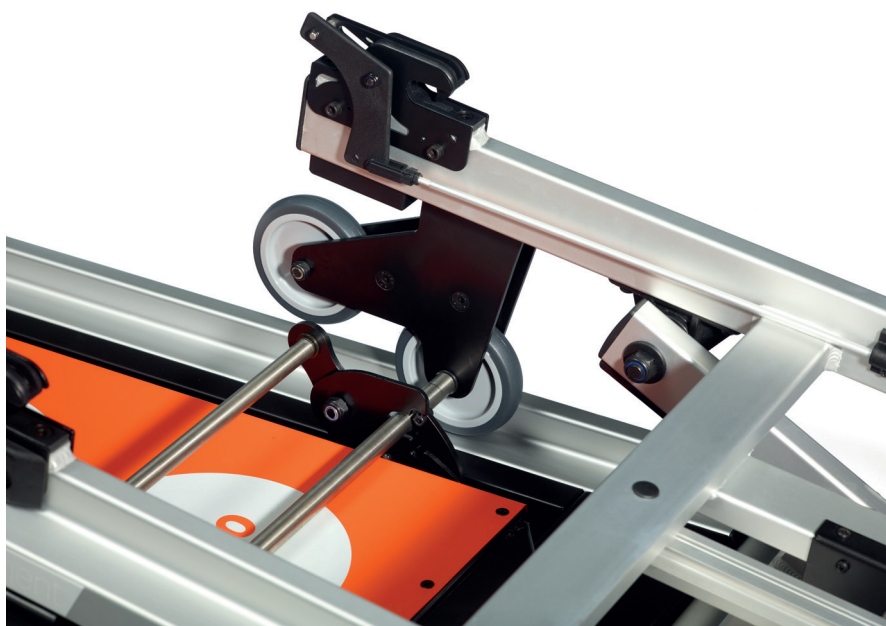

Made in Portugal

 **A200**equipment

Head Office
Rua de S. Caetano
459 / 519 - Apartado 526
4411-701 Canelas,
V. N. Gaia, Portugal

South delegation
Rua Olival Minas, n.º 7
Quintanilho
Apartado 02, EC Vialonga
2626-908 Vialonga

www.autoribeiro.com
comercial@autoribeiro.com
T. +351 227 157 100 · Porto
F. +351 227 121 144 · Porto
T. +351 210 998 814 · Lisboa

Cofinanciado por:

COMPETE 2020
PROGRAMA OPERACIONAL COMPETITIVIDADE E INOVACIONALIDADE

PORTUGAL 2020

 UNIÃO EUROPEIA
Fundo Europeu
de Desenvolvimento Regional

EN 1865-5

10G

Weight:

104.1 kg

Dimensions:

1930 x 605 x 345 mm

Equipped with:

Security system with power cut

Auxiliary system for manual movement

12V DC Power

Warranty:

2 years



Electric main system

Electric driving equipment by control



▲ Hand crank

Manual alternative in case of power failure