

M764

Camilla
monoblock 4SW

arequipment



M764. Camilla monoblock 4SW.

- Estructura en aluminio
- 4 puños extensibles en 175mm
- 4 ruedas giratorias con diámetro 200mm
- Inclinación ajustable de la cabecera en 8 posiciones
- Inclinación ajustable de la cobertura de los pies en 3 posiciones

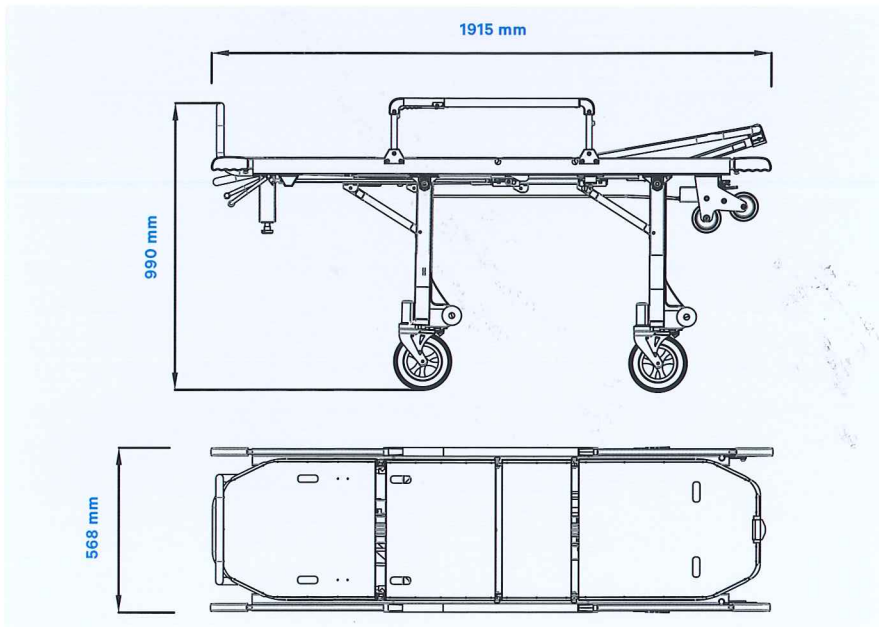

EN 1865-1

10G

Peso:

44,7 kg

Carga Máxima:

250 kg

Dimensiones (cerrado):

1915 x 568 x 455 mm

Dimensiones (abierto):

1915 x 568 x 990 mm

Equipado con:

Soporte de suero

Apoyabrazos ajustables

Apoya pies

Cinturón de fijación tipo chaleco

Cinturón de fijación para cintura y piernas

Garantía:

2 años



Made in Portugal



ARIequipment

Rua de S. Caetano 459 / 519
Apartado 526
4411-701 Canelas, V. N. Gaia,
Portugal

www.autoribeiro.pt
autoribeiro@autoribeiro.pt
+351. 227 157 100
+351. 227 121 144 (F)

